

Sensors Data Fusion Architecture Over MIMO: Case Study of Quad copter

Charan Arur Panem, A. A. Gaonkar, U. V. Rane, A. B. Pandit, R. S. Gad*

ALTERA SoC laboratory, Department Of Electronics, Goa University, Goa, India

{panem.charan@gmail.com, anik9230@gmail.com, udaysingvrane@gmail.com, ameypandit1987@yahoo.com,

*rsgad@unigoa.ac.in}

Abstract— Nowadays wireless communication systems use multiple antennas at transmitting and receiving end to offer improved capacity and data rate over single antenna systems in multipath channels. MIMO channels provide a number of advantages over conventional Single Input Single Output (SISO) channels such as the array gain, the diversity gain, and the multiplexing gain. In this paper we have introduced sensor level Data Fusion for 2X2 MIMO system. We have discussed generalized MIMO systems wherein the signals on the transmitting (Tx) antennas and the receiving (Rx) antennas for the quality (bit-error rate or BER) or the data rate (bits/sec) of the channel for each MIMO. We focus on the Spatial Multiplexing technique of MIMO systems. Here different fading channels like AWGN are used for analysis purpose. The 2X2 MIMO system performance is analyzed in terms of BER (bit error rate) v/s SNR (signal to noise ratio). The system is customized for the Quadcopter for the sensors, like gyrometer, accelerometer and temperature to transmit them over the wireless channel for optimum bandwidth utilization. The said system is demonstrated for the proper BER over RC-channel at bandwidth of 2.4GHz over RF frequency of 3-30MHz.

Keywords: MIMO, DataRate, Capacity, SNR, BER, Kalman filter.

I. INTRODUCTION

MIMO wireless technology is able to considerably increase the capacity of a given channel. By increasing the number of receive and transmit antennas it is possible to linearly increase the throughput of the channel with every pair of antennas added to the system. This makes MIMO wireless technology one of the most important wireless techniques to be employed in recent years. As spectral bandwidth is becoming an ever more valuable commodity for radio communications systems its required to use the available bandwidth more effectively [1]. MIMO wireless technology is one of these techniques. Multiple Input Multiple Output (MIMO) antenna systems are used in modern wireless standards like IEEE 802.11n, 3GPP LTE and mobile WiMAX(4G) Systems. The technique supports enhanced data throughput even under conditions of interference, signal fading and multipath. MIMO, is a radio communications technology or RF technology that is being mentioned and used in many new technologies these days[2]. The Wi-Fi, LTE (3G long term evolution) and many other radio, wireless and RF technologies are using the new MIMO wireless technology to provide increased link capacity and spectral efficiency combined with improved link reliability.

Wireless sensor networks (WSNs) have been successfully used to support various civilian and military applications [3]. These networks are sometimes operated in harsh or adversarial

environments, e.g., space missions, oceanic exploration, underground monitoring, battlefields, etc., making it expensive or impossible to replace their batteries.

Hence, it is critical to design the network to be an energy-efficient. Many researchers advocate using cooperative communications to conserve energy by having groups of nodes cooperate in transmitting or receiving data. Often they specifically address the questions of how, when, and whom to cooperate with, so as to prolong the network lifetime. Cooperative communications and references there in exploit the spatial diversity that arises from transmitting the same signal (or highly correlated versions of it) over several, spatially separated antennas [7]. As such, the theory of cooperative communications is closely related to MIMO technology. Under a given power budget and fading conditions, MIMO communications offer much higher throughput (spatial multiplexing gain) or more reliable communications (diversity gain) than single input single output (SISO) systems can be used to provide diversity gain.

WSN is capable of performing various mechanisms such as self-configuration, multi-hop communication, energy efficient operations, in-network processing, data centric and content based networking, scheduling, time synchronization topology and routing[6]. AWGN (additive white Gaussian Noise), by using one of the standard built-in functions in MATLAB. The noisy signal then becomes the input to the receiver. The receiver demodulates the signal, producing a sequence of recovered bits. The FCS (Frame Check Sequence) is recomputed at the receiver to find whether there was an error in the transmitted packet. Finally, compare the received bits to the transmitted bits and tally up the errors. Bit-error-rate (BER) performance is depicted by plotting BER at a series of different SNRs (Signal to Noise Ratio) [5].

II. PROPOSED ARCHITECTURE FOR SENSOR DATA FUSION OVER MIMO

A. Data Fusion Mythologies

Data fusion is the process of integration of multiple data and knowledge representing the same real-world object into a consistent, accurate, and useful representation. Data fusion techniques have been extensively employed on multi sensor environments with the aim of fusing and aggregating data from different sensors; however, these techniques can also be applied to other domains, such as text processing. The goal of using data fusion in multisensor environments is to obtain a

lower detection error probability and a higher reliability by using data from multiple distributed sources .

In general, all tasks that demand any type of parameter estimation from multiple sources can benefit from the use of data/information fusion methods. The term information fusion and data fusion are typically employed as synonyms; but in some scenarios, the term data fusion is used for raw data (obtained directly from the sensors) and the term information fusion is employed to define already processed data. In this sense, the term information fusion implies a higher semantic level than data fusion. Other terms associated with data fusion that typically appear in the literature include decision fusion, data combination, data aggregation, multisensor data fusion, and sensor fusion. The different types of sensor fusion are proposed in literature as described below.

B. Three-Level Categorization

Fusion processes are often categorized in a three-level model distinguishing low, intermediate, and high level fusion. Low-level fusion or raw data fusion or data association, combines several sources of raw data to produce new data that is expected to be more informative than the inputs. The Second Intermediate-level fusion or feature level fusion or state estimation, combines various features such as edges, corners, lines, textures, or positions into a feature map that may then be used for segmentation and detection. Third High-level fusion or decision fusion, combines decisions from several experts. Methods of decision fusion include voting, fuzzy-logic, and statistical methods.

C. Classification Based on the Relations between the Data Sources

The Fig.1 describes the fusion methodology based on data sources. One can see the environment in which various characteristics sensors types are embedded for monitoring ambient conditions. One can see various types of fusion at sensor level which are describe below.

- Sensors in a competitive configuration have each sensor delivering independent measurements of the same property. Competitive configurations are used for fault tolerant and robust systems. An example would be the reduction of noise by combining two overlaying camera images. Sensor S1 and S2 in figure1 represent a competitive configuration, where both sensors redundantly observe the same property of an object in the environment space.

- A sensor configuration is called complementary if the sensors do not directly depend on each other, but can be combined in order to give a more complete image of the phenomenon under observation. This resolves the incompleteness of sensor data. An example for a complementary configuration is the employment of multiple cameras each observing dis junct parts of a room. Generally, fusing complementary data is easy, since the data from independent sensors can be appended to each other. Sensor S2 and S3 in figure.1 represent a complementary configuration, since each sensor observes a different part of the environment space,

A sensor configuration is called complementary if the sensors do not directly depend on each other, but can be combined in order to give a more complete image of the phenomenon under observation. This resolves the incompleteness of sensor data. An example for a complementary configuration is the employment of multiple cameras each observing disjunct parts of a room. Generally, fusing complementary data is easy, since the data from independent sensors can be appended to each other. Sensor S2 and S3 in figure.1 represent a complementary configuration, since each sensor observes a different part of the environment space.

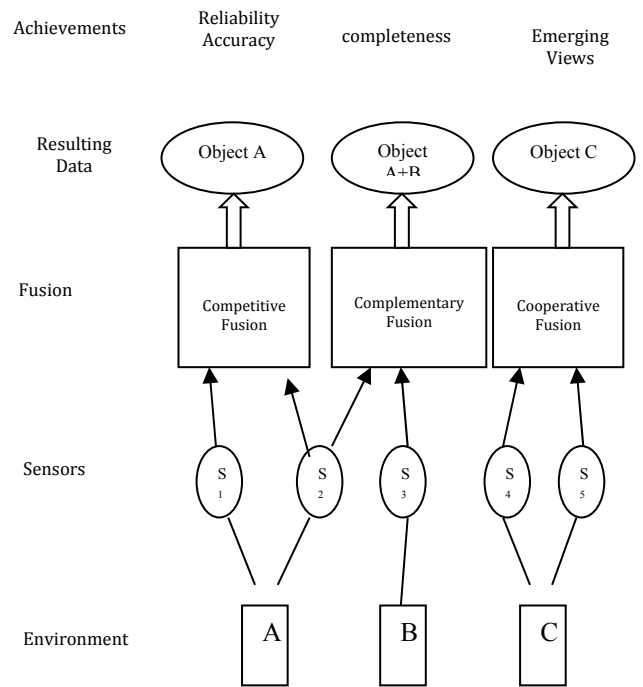

Fig.1. Classification Based on the Relations between the Data Sources

A cooperative sensor network uses the information provided by two independent sensors to derive information that would not be available from the single sensors. An example for a cooperative sensor configuration is stereoscopic vision – by combining two-dimensional images from two cameras at slightly different viewpoints a three-dimensional image of the observed scene is derived. Sensor S4 and S5 in fig.1 represent a cooperative configuration. Both sensors observe the same object, but the measurements are used to form an emerging view on object C that could not have been derived from the measurements of S4 or S5 alone.

These three categories of sensor configuration are not mutually exclusive. Many applications implement aspects of more than one of the three types. An example for such a hybrid architecture is the application of multiple cameras that monitor a given area. In regions covered by two or more cameras the sensor configuration can be competitive or

cooperative. For regions observed by only one camera the sensor configuration is complementary. MIMO can be sub-divided into three main categories i.e. precoding, spatial multiplexing(SM) and diversity coding. Precoding is multi-stream beam forming method.

In more general terms, it is considered to be all spatial processing that occurs at the transmitter. In (single-stream) beam forming, the same signal is emitted from each of the transmit antennas with appropriate phase and gain weighting such that the signal power is maximized at the receiver input. The benefits of beam forming are to increase the received signal gain by making signals emitted from different antennas add up constructively and to reduce the multipath fading effect. In line-of-sight propagation, beamforming results in a well-defined directional pattern. However, conventional beams are not a good analogy in cellular networks, which are mainly characterized by multipath propagation. When the receiver has multiple antennas, the transmit beamforming cannot simultaneously maximize the signal level at all of the receive antennas, and precoding with multiple streams is often beneficial.

Spatial multiplexing requires MIMO antenna configuration. In spatial multiplexing, a high-rate signal is split into multiple lower-rate streams and each stream is transmitted from a different transmit antenna in the same frequency channel. If these signals arrive at the receiver antenna array with sufficiently different spatial signatures and the receiver has accurate Channel State Information (CSI), it can separate these streams into (almost) parallel channels. Spatial multiplexing is a very powerful technique for increasing channel capacity at higher signal-to-noise ratios (SNR). The maximum number of spatial streams is limited by the lesser of the number of antennas at the transmitter or receiver. Spatial multiplexing can be used without CSI at the transmitter, but can be combined with pre-coding if CSI is available. Spatial multiplexing can also be used for simultaneous transmission to multiple receivers, known as space-division multiple access or multi-user MIMO, in which case CSI is required at the transmitter. The scheduling of receivers with different spatial signatures allows good separability.

Diversity Coding techniques are used when there is no channel knowledge at the transmitter. In diversity methods, a single stream (unlike multiple streams in spatial multiplexing) is transmitted, but the signal is coded using techniques called space-time coding. The signal is emitted from each of the transmit antennas with full or near orthogonal coding. Diversity coding exploits the independent fading in the multiple antenna links to enhance signal diversity. Because there is no channel knowledge, there is no beamforming or array gain from diversity coding. Diversity coding can be combined with spatial multiplexing when some channel knowledge is available at the transmitter.

In MIMO systems, a transmitter sends multiple streams by multiple transmit antennas. The transmit streams go through a matrix channel which consists of all $NtNr$ paths between

the Nt transmit antennas at the transmitter and Nr receive antennas at the receiver. Then, the receiver gets the received signal vectors by the multiple receive antennas and decodes the received signal vectors into the original information. A narrowband flat fading MIMO system is modelled as shown in eq.(1)

$$Y=Hx+n.....(1)$$

where Y and X are the receive and transmit vectors, respectively, and H and n are the channel matrix and the noise vector, respectively.

D. MIMO configurations

The maximum channel capacity of a MIMO system, the channel capacity can be estimated as a function of N spatial streams. A basic approximation of MIMO channel capacity is a function of spatial streams, bandwidth, and signal-to-noise ratio (SNR) and is shown in the following Eq.2, where BW is bandwidth of channel

$$\text{Capacity} = N \text{ BW} \log_2 (1 + \text{SNR}).....(2)$$

Given the equation for MIMO channel capacity, it is possible to investigate the relationship between the number of spatial streams and the throughput of various implementations of SISO and MIMO configurations.

Benefits of MIMO Technology:

(1) Multiple antenna configurations can be used to overcome the detrimental effects of multi-path and fading when trying to achieve high data throughput in limited-bandwidth channels. Multiple-input, multiple-output (MIMO) antenna systems are used in modern wireless standards, including in IEEE 802.11n, 3GPP LTE, and mobile WiMAX systems. The technique supports enhanced data throughput even under conditions of interference, multi-path and fading. The demand for higher data rates over longer distances has been one of the primary motivations behind the development of MIMO orthogonal- frequency-division-multiplexing (OFDM) communications systems.

(2) Superior Data Rates, Range and Reliability Systems with multiple antennas at the transmitter and receiver also referred to as Multiple Input Multiple Output (MIMO) systems offer superior data rates, range and reliability without requiring additional bandwidth or transmit power. By using several antennas at both the transmitter and receiver, MIMO systems create multiple independent channels for sending multiple data streams.

E. Sensors level data fusion Architecture over MIMO

The proposed architecture collects the data i.e. $Y_1(t), Y_2(t), \dots, Y_n(t)$, from various sensors which is then conditional for signal for appropriate formats, which generates $Y'_1(t), Y'_2(t), \dots, Y'_n(t)$ signal. Thus formats are further at sensor data level to generate $Y''_{11}(t), Y''_{12}(t), Y''_{13}(t), \dots, Y''_{mm}(t)$ signals. Here $m \leq n$ which depends on how many sensors are fused shown fig.2. The fused data is further modulated using proper modulation techniques e.g. BPSK, QPSK... etc. and then transmitted over MIMO system with

proper channel coding methods over guided or unguided channel having AWGN characteristics.

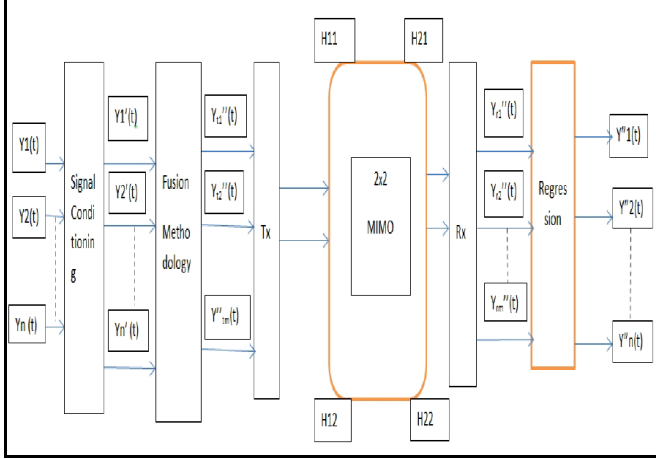

Fig.2.Proposed Architecture For Sensor Data Fusion Over MIMO.

The Received signal is later demodulated using same technique as at transmitter to receive the transmitted signal and further decoded for the channel codes. The received signal $Y''_{r1}(t), Y''_{r2}(t), Y''_{r3}(t) \dots Y''_{rm}(t)$ is later regressed using proper regression methodology like e.g. PLSR to reconstruct the fused data i.e. $Y''_1(t), Y''_2(t), \dots, Y''_n(t)$.

F. Customized Case For Quadcopter

Here the architecture is customized for quadcopter using 2x2 MIMO system, the advantages of this system is that the multiple antenna configurations can be used to overcome the detrimental effects of multi-path and fading when trying to achieve high data throughput in limited-bandwidth channels, and also the Superior Data Rates, Range and Reliability. One can see that the three axis Gyrometer and Accelerometer is used for the prediction of the position of the x, y, z coordinated for positioning the Quadcopter. These measured values are fused with the complementary and Kalman filter to estimate the values of the positions. The complementary filter is implemented using the discrete state space as shown in the Fig. 4. The Kalman filter estimate the parameter obtained from the complementary filter 'Z_k' i.e. angle as shown in Eq. 3. In every iteration, the Kalman filter will change the variables in the linear model a bit, so the output of the linear model will be closer to the second input. To calculate the Kalman parameter i.e. angle

$$X_k = K_k \cdot Z_k + (1 - K_k) \cdot X_{k-1} \dots \dots \dots (3)$$

here 'k' on the subscript are states (k=1,2,...n). The purpose is to find X_k, the estimate of the signal X. And we wish to find it for each consequent k's. Also, here Z_k is the measurement value. K_k is called "Kalman Gain" (which is usually started with value of 0.5 during tuning the Kalman filter), and X_{k-1} is the estimate of the signal on the previous state. The only unknown component in this equation is the Kalman Gain K_k.

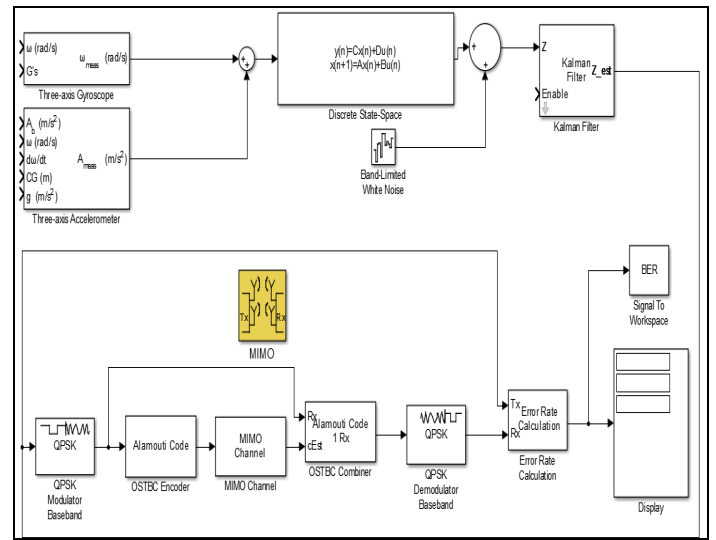

Fig.3.Customized Case 2x2 MIMO using Simulink

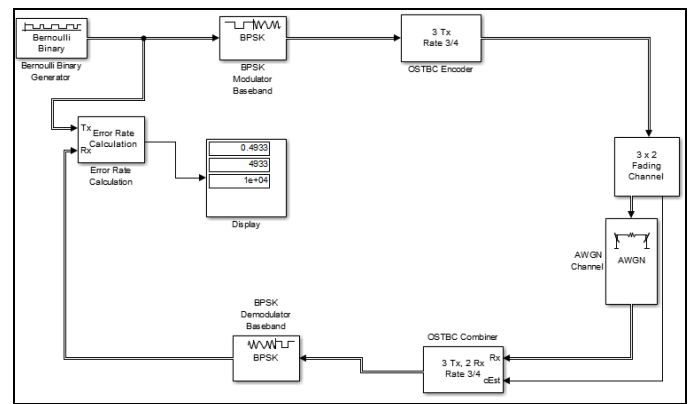

Fig.4.Customized BPSK Modulation Simulink Model

The estimated parameter is further modulated using QPSK and transmitted over the 2 x 2 MIMO channel using proper channel coding methodology i.e. Block code or convolution codes. Later the system is verified for the BER and SNR. One can see two methods of bandwidth efficiency i.e. one is data reduction using fusion technique and seconds is MIMO for transmission over RC channel.

Using BPSK Modulation over the MIMO channel using OSTBC Codes. It is verified BER and SNR shown Fig.4 and plot shown the Fig.6.

III. RESULTS AND DISCUSSION

The results for the fusion are presented in the Fig. 4. Here we have demonstrated the signal acquired from the quadcopter over guided channel without channel coding. The estimated data over the Kalman filter is generated after proper fusion after tuning the Kalman gain.

The result shown in Fig. 5 i.e. (Combination of Gyro and Accelerometer without any filtering):

- The Red signal is the raw tilt angle (Accelerometer signal) which is noisy.
- The Green signal is the gyro signal which is a very clean signal but contain a lot of drift over time.

- The Blue signal is the output of a Kalman Filter which gets the advantages of these two signals and eliminates the disadvantages of the signal mentioned.

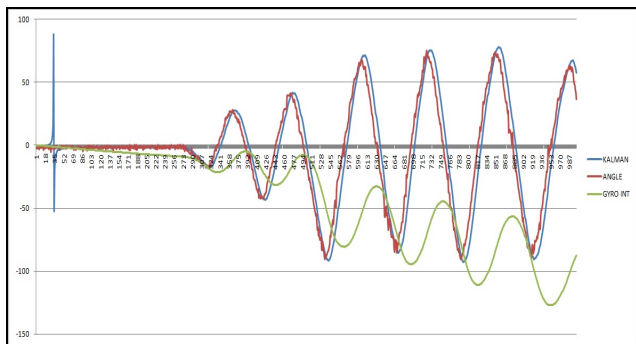

Fig.5. Kalman filter for the Gyro and Accelerometer.

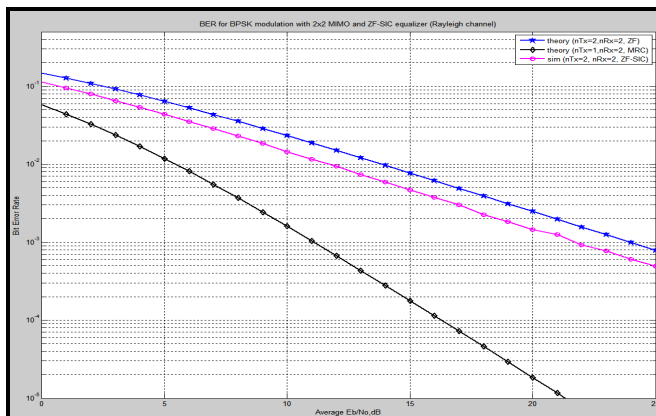

Fig.6. The simulation results of MIMO system

Spatial multiplexing techniques make the receivers very complex, and therefore they are typically combined with Orthogonal frequency-division multiplexing (OFDM) or with Orthogonal Frequency Division Multiple Access (OFDMA) modulation, where the problems created by a multi-path channel are handled efficiently. MIMO are used in Mobile radio telephone standards such as recent 3GPP and 3GPP2. In 3GPP, High-Speed Packet Access plus (HSPA+) and Long Term Evolution (LTE) standards take MIMO configuration is used. Moreover, to fully support cellular environments, MIMO research consortia including IST-MASCOT propose to develop advanced MIMO techniques, e.g., multi-user MIMO (MU-MIMO).

ACKNOWLEDGMENT

Authors would like to acknowledge financial assistance from Department of Electronics and Information Technology (DeitY, New Delhi) for financial assistance under the Visveshvaraya PhD Scheme and ALTERA Inc. USA for financial the support under University Program.

REFERENCES

1. Junil Choi, David J. Love, D. Richard Brown, "Quantized Distributed Reception for MIMO Wireless Systems Using Spatial Multiplexing", IEEE Transactions On Signal Processing, Vol. 63, No. 13, July 1, 2015
2. Distributed Antenna Systems and MIMO Technology, LTE wireless and service technology.
3. Morris Filippi, Yannick Le Moullec, Andrea Fabio Cattoni "SDR Implementation of a OFDM-MIMO Receiver".
4. Sunil Joshi, PC Bapna, Neha Kothari "Bit Error Rate Performance of MIMO Channels for various Modulation Schemes using Maximum Likelihood Detection Technique, IP Multimedia Communications A Special Issue from IJCA www.ijcaonline.org
5. U. V. Rane, V. R. Gad, R. S. Gad*, G. M. Naik, "Reliable and Scalable Architecture for Internet of Things for Sensors Using Soft-Core Processor", International of Things, Smart Spaces, and next Generation Networks and Systems, proceedings August 26-28, 2015, Springer LNCS9247
6. Vinay R. Gad, R. S. Gad*, G. M. Naik, "Configurable CRC Error Detection Model For performance analysis of polynomial: Case study for the 32-bits", International of Things, Smart Spaces, and next Generation Networks and Systems, proceedings August 26-28, 2015, Springer LNCS9247
7. George V. Tsoulos "MIMO System Technology for Wireless Communications".
8. Prof. Gajanan R Patil, Prof. V K Kokate "Simulation Study of Some Spatial Diversity Techniques for MIMO Wireless Communication Systems, International Journal of Emerging Technology and Advanced Engineering Volume 2, Issue 12, December 2012,
9. C. E. A. Mulligan and M. Olsson, "Architectural implications of smart city business models: An evolutionary perspective," IEEE Commun. Mag., vol. 51, no. 6, pp. 80–85, Jun. 2013.
10. N. Walravens and P. Ballon, "Platform business models for smart cities: From control and value to governance and public value," IEEE Commun. Mag., vol. 51, no. 6, pp. 72–79, Jun. 2013.
11. J. P. Lynch and J. L. Kenneth, "A summary review of wireless sensors and sensor networks for structural health monitoring," Shock and Vibration Digest, vol. 38, no. 2, pp. 91–130, 2006.
12. T. Nuortio, J. Kytöjoki, H. Niska, and O. Bräysy, "Improved route planning and scheduling of waste collection and transport," Expert Syst. Appl., vol. 30, no. 2, pp. 223–232, Feb. 2006.
13. A. R. Al-Ali, I. Zualkernan, and F. Aloul, "A mobile GPRS-sensors array for air pollution monitoring," IEEE Sensors J., vol. 10, no. 10, pp. 1666–1671, Oct. 2010.
14. N. Maisonneuve, M. Stevens, M. E. Niessen, P. Hanappe, and L. Steels, "Citizen noise pollution monitoring," in Proc. 10th Annu. Int. Conf. Digital Gov. Res.: Soc. Netw.: Making Connec. Between Citizens, Data Gov., 2009, pp. 96–103.
15. X. Li, W. Shu, M. Li, H.-Y. Huang, P.-E. Luo, and M.-Y. Wu, "Performance evaluation of vehicle-based mobile sensor networks for traffic monitoring," IEEE Trans. Veh. Technol., vol. 58, no. 4, pp. 1647–1653, May 2009.
16. G. Montenegro, N. Kushalnagar, J. Hui, and D. Culler, Transmission of IPv6 packets over IEEE 802.15.4 networks, RFC4944, s.l.: IETF Sep. 2007. [Online]. Available: <http://tools.ietf.org/html/rfc4944>.
17. IEEE Standard for Local and Metropolitan Area Networks—Part 15.4: Low-Rate Wireless Personal Area Networks (LR-WPANs), IEEE Standard 802.15.4-2011.
18. C.-F. Huang, H.-W. Lee, and Y.-C. Tseng, "A Two-Tier Heterogeneous Mobile Ad Hoc Network Architecture and Its Load-Balance Routing," IEEE VTC-Fall, 2003.
19. C. K. Toh, A.-N. Le, and Y.-Z. Cho, "Load Balanced Routing Protocols for Ad Hoc Mobile Wireless Networks," IEEE Commun. Mag., vol. 47, no. 8, 2009, pp. 78–84.
20. H. Jiang and S. Rappaport, "CBWL: A New Channel Assignment and Sharing Method for Cellular Communication Systems," IEEE Trans. Vehic. Tech., vol. 43, no. 2, May 1994, pp. 313–22.